

■ W136 - W135 - W123



Cric idropneumatici per camion

Hydropneumatic heavy duty jacks

Crics hydropneumatiques pour poids lourds

Hydropneumatische LKW-Heber



- Costruzione robusta per lavoro intensivo
- Ruote con cuscinetto a sfera
- Valvola limitatrice di carico
- Heavy duty design
- Wheels with ball bearings
- Overload safety valve
- Construction très robuste pour travail intensif
- Roulettes avec roulement à billes
- Soupape de surcharge
- Sehr robuste Konstruktion für intensive Arbeiten
- Kugelgelagerte Räder
- Überlastventil

WERTHER



W136 - W135 - W123

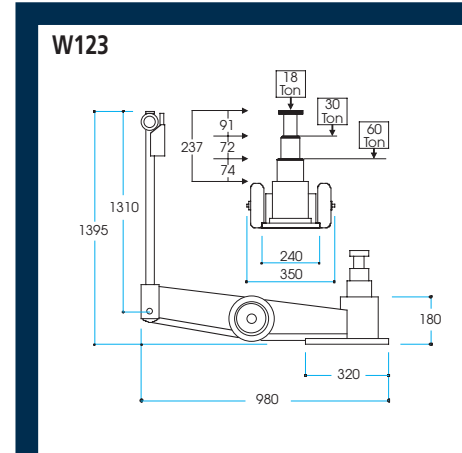
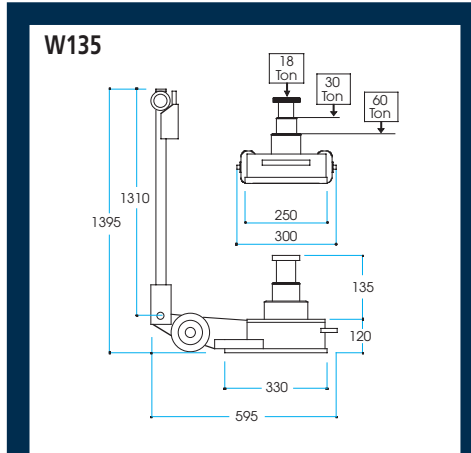
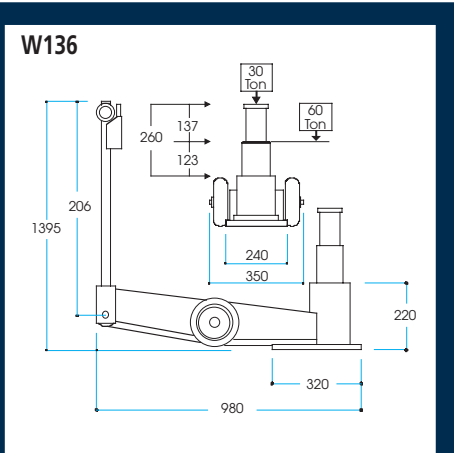

Dati tecnici - Technical data - Caractéristiques techniques - Technische Eigenschaften

	W136	W135	W123
Portata / Capacity / Capacité / Tragkraft	60/30 t	60/30/18 t	60/30/18 t
Peso / Weight / Poids / Gewicht	72 kg	47 kg	70 kg
Pressione / Pressure / Pression / Luftdruck	8-12 bar	8-12 bar	8-12 bar



WERTHER INTERNATIONAL S.p.A.

Via F. Brunelleschi, 12 - 42040 Cadè (RE) Italy - Tel. ++39 0522 9431 - Fax ++39 0522 941997

www.wertherint.com - e-mail: sales@wertherint.com

Il fabbricante, nell'ambito del costante miglioramento dei propri prodotti, si riserva il diritto di apportare modifiche senza preavviso. - The company reserves the right to introduce improvements in design or specification without prior notice. - Der Hersteller behält sich das Recht vor, im Zuge der technischen Weiterentwicklung, technische Eigenschaften ohne Vorankündigung zu ändern. - Le fabricant dans le but d'améliorer constamment ses produits, se réserve le droit d'apporter des modifications sans préavis - La compañía Werther se reserva de todos modos el derecho de aportar todas las modificaciones que considera necesarias para mejorar la estética o el funcionamiento de los productos, sin tener la obligación de avisar de ello.