

■ W107 - W107SE - W107LP - W107SE/LP - W107SE/LPG
 W108 - W108SE - W108LP - W108SE/LP - W108SE/LPG



Gru idraulica pieghevole

Hydraulic folding crane

Grue hydraulique pliable

**Hydraulischer, klappbarer
Kran**



	SE		LP		G	
Modello	Con pompa a semplice effetto	Con pompa a doppio effetto	Basso profilo (gambe)	Pompa pivotante	Portata	
Model	With single action pump	With double action pump	Low profile (legs)	Pivoting pump	Capacity	
Modèle	Avec pompe simple effet	Avec pompe double effet	Profil surbaissé (pieds)	Pompe pivotante	Capacité	
Modell	Mit einfachwirkender Pumpe	Mit doppelwirkender Pumpe	Niedrige Bauhöhe (Beine)	Drehbar gelagerte Pumpe	Tragkraft	
W107		X				500 kg
W107SE	X					500 kg
W107LP		X	X			500 kg
W107SE/LP	X		X			500 kg
W107SE/LP G	X		X	X		500 kg
W108		X				1000 kg
W108SE	X					1000 kg
W108LP		X	X			1000 kg
W108SE/LP	X		X			1000 kg
W108SE/LP G	X		X	X		1000 kg

WERTHER



W107 -W107SE -W107LP -W107SE/LP-W107SE/LPG W108 -W108SE -W108LP -W108SE/LP-W108SE/LPG

Dati tecnici - Technical data - Caractéristiques techniques - Technische Eigenschaften

	W107 W107SE	W108 W108SE	W107SE/LP W107LP W107SE/LPG	W108SE/LP W108LP W108SE/LPG
A	1600	1650	1580	1595
B	1540	1560	1490	1505
C	1200	1345	1200	1345
D	900	1080	900	1055
E	140	165	85	85
F	330	470	385	480
H	1940	2220	1875	2185
I	2070	2400	2005	2390
L	720	835	700	760
M	885	1000	905	1010
N	440	550	450	550
kg	80	110	85	118

LP = RIBASSATO
LP = SURBAISSE
LP = LOW PROFILE
LP = TIEFE GESETZT

G = Pompa pivotante
Pivoring pump
Pompe pivotante
Drehbar gelagerte Pumpe

(Kg)

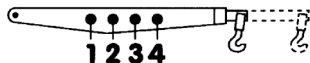

1	500	1000	500	1000
2	400	800	400	800
3	350	650	350	650
4	250	450	250	450

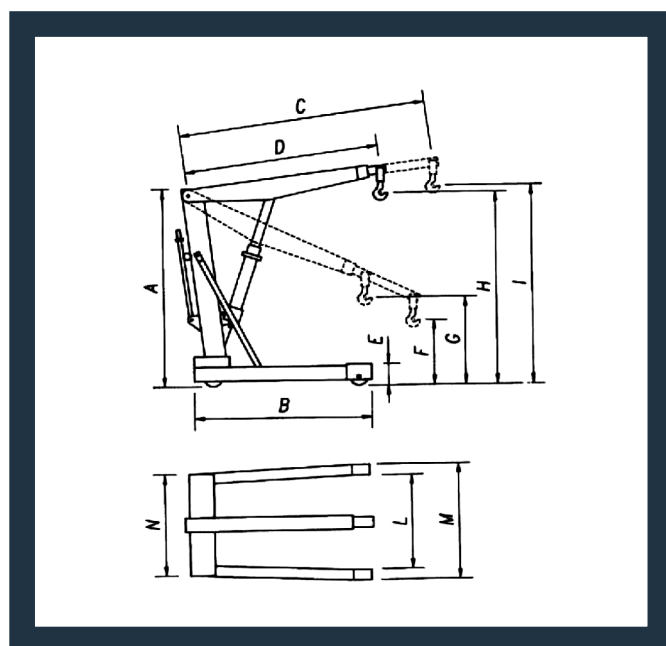

- Valvola limitatrice di carico
- Comando tipo uomo presente
- Comando di discesa proporzionale

- Overload safety-valve
- Feet guards
- Proportional lowering control

- Sécurité hydraulique en cas de surcharge
- Commande de type "homme mort"
- Commande de descente proportionale

- Überlastventil
- Totmann-Senksteuerung
- Proportionale Senksteuerung



Pompa pivotante
Pivoring pump
Pompe pivotante
Drehbar gelagerte Pumpe



WERTHER INTERNATIONAL S.p.A.

Via F. Brunelleschi, 12 - 42040 Cadè (RE) Italy - Tel. ++39 0522 9431 - Fax ++39 0522 941997

www.wertherint.com - e-mail: sales@wertherint.com

Il fabbricante, nell'ambito del costante miglioramento dei propri prodotti, si riserva il diritto di apportare modifiche senza preavviso. - The company reserves the right to introduce improvements in design or specification without prior notice. - Der Hersteller behält sich das Recht vor, im Zuge der technischen Weiterentwicklung, technische Eigenschaften ohne Vorankündigung zu ändern. - Le fabricant dans le but d'améliorer constamment ses produits, se réserve le droit d'apporter des modifications sans préavis. - La compagnia Werther se riserva de todos modos el derecho de aportar todas las modificaciones que considera necesarias para mejorar la estética o el funcionamiento de los productos, sin tener la obligación de avisar de ello.