

450AT/5



5

SOLLEVATORE A 4 COLONNE

4 POST LIFT

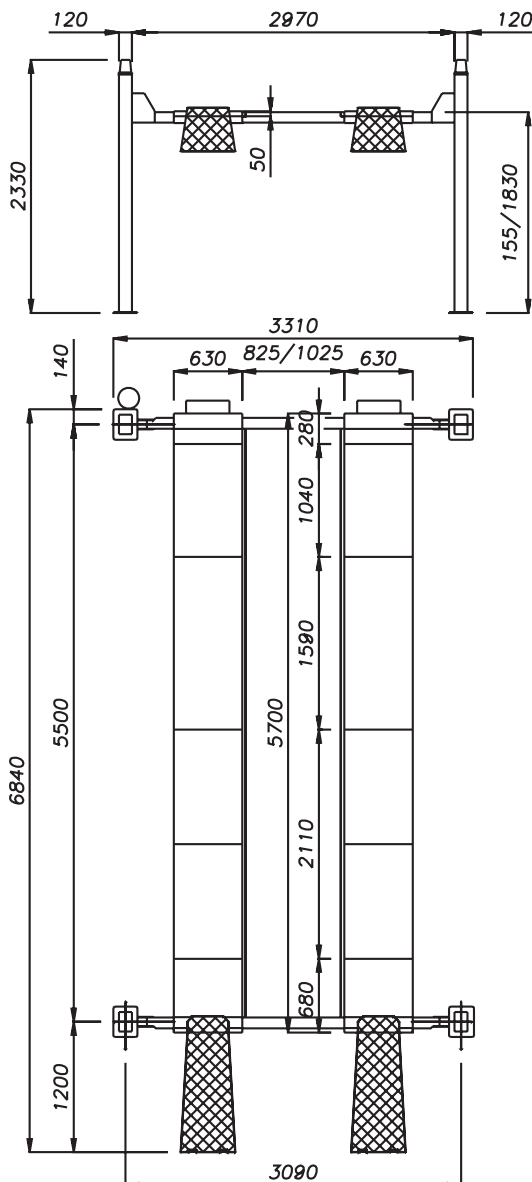

OPTIONAL V0164

Piatti rotanti
Plates tournantes
Turn plates
Drehplatten





450AT/5 Sollevatore elettroidraulico a 4 colonne per assetto ruote con incavo per piatti rotanti, alta velocità
 Pont élévateur électrohydraulique 4 colonnes pour contrôle train-avant avec encoches antérieurs pour plates tournantes, grand vitesse

Electro-hydraulic 4 post-lift for wheel alignment with front recess for turn plates, high speed lifting and lowering
 Elektrohydraulische 4-Säulen Hebebühne für Lenkgeometrie Einstellung mit vorderer Einspannung für Drehplatten, hohe Hubgeschwindigkeit

- | | | | |
|---|---|--|---|
| <ul style="list-style-type: none"> ● Sicurezza in caso di rottura fune ● Sicurezza idraulica in caso di sovraccarico ● Valvola di controllo velocità discesa ● Valvola sicurezza in caso di rottura tubo idraulico ● Comandi uomo presente 24V ● Comando sgancio elettrico ● Avvisatore acustico fase finale discesa | <ul style="list-style-type: none"> ● Sécurité en cas de rupture du câble ● Sécurité hydraulique en cas de surcharge ● Vanne de contrôle descente ● Vanne de sécurité hydraulique en cas de rupture de tuyauterie ● Commande de type "homme mort" 24V ● Déverrouillage à commande électrique ● Avertisseur acoustique phase finale descente | <ul style="list-style-type: none"> ● Safety device in case of rope breaking ● Overload safety-device ● Descent control valve ● Safety-valve in case of sudden loss of pressure ● "Dead man" controls 24V ● Electrical controlled fall safety ● Acoustic warning final descent phase | <ul style="list-style-type: none"> ● Feststellvorrichtung in fall von Seilabbruch ● UL-Sicherheitsventil ● Absenk-Kontroll-Ventil ● SB-Sicherheitsventil ● Totmannknopf-Schaltung 24V ● Elektrische Auslösung der Sicherheitsarretierung ● Akustisches Signal Endphase Abstieg |
|---|---|--|---|

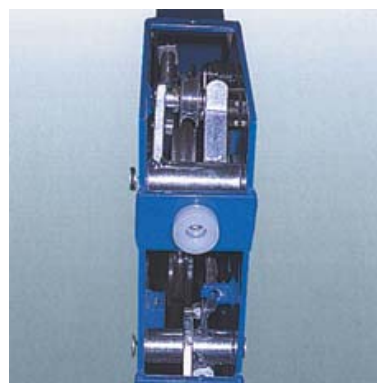
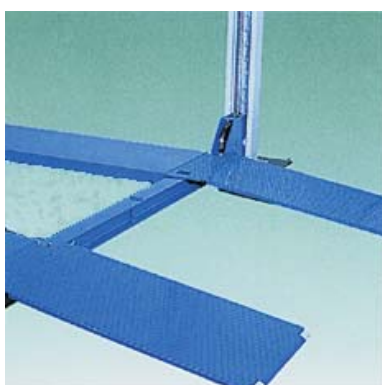

DATI TECNICI	DONNES TECHNIQUES	TECHNICAL DATES	TECHNISCHE DATEN		450AT/5
Portata	Capacité	Capacity	Tragfähigkeit	t	5
Motore trifase	Moteur triphase	Three-phase motor	3-Phasen-Motor	kw	3
Tensione	Voltage	Voltage	Spannung	V/Hz	230-400/50
Salita	Montée	Lifting	Hubzeit	sec	30
Discesa	Descente	Descent	Absenkzeit	sec	30
Peso	Poids	Weight	Gewicht	kg	1230

La ditta si riserva la facoltà di apportare modifiche alle proprie macchine in qualsiasi momento e senza preavviso.

Notre Maison se réserve d'apporter des modifications aux machines n'importe sans quand préavis.

The manufacturing Company reserves the right to make modifications to its machines at any time without notice.

Der Erzeuger behält sich das Recht vor, jederzeit und ohne Vorankündigungen, Veränderungen an den eigenen Geräten durchzuführen.