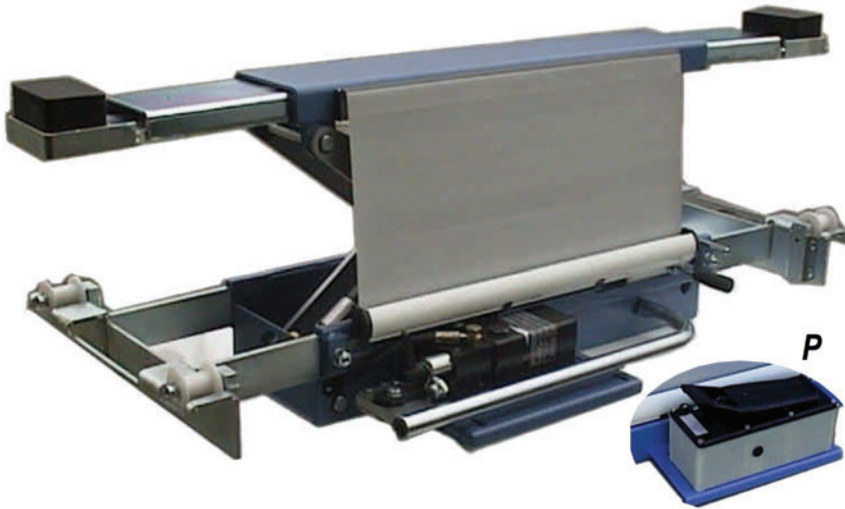

# 401M/401P

**1,8 t**

Traverse idrauliche  
Hydraulic jacking beams  
Traverses hydrauliques  
Hydraulische Achsfreiheber

Modelli disponibili / Available versions / Versions disponibles / Lieferbare Ausführungen

Per sollevatore / Ideal on lift model / Idéal sur le pont élévateur / Für Hebebühnenmodell

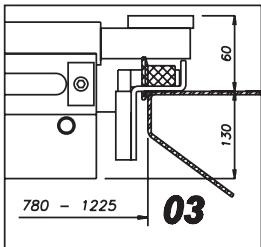

450 LT  
450 ATLT

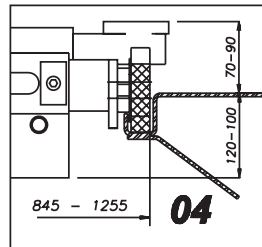

443, 442LP

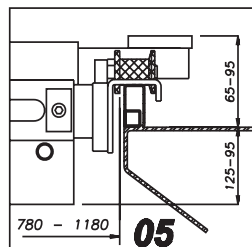

430, 430 BL, 435, 436,  
450 AT, SATURNUS 45

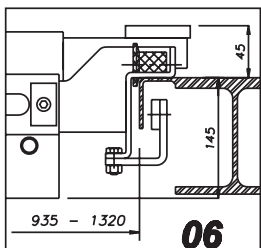

460

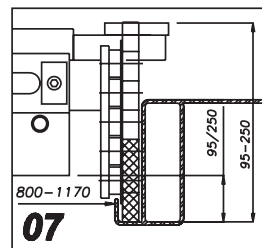

VARI

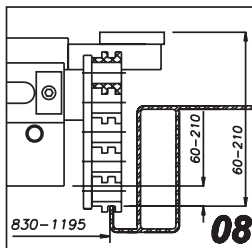

VARI

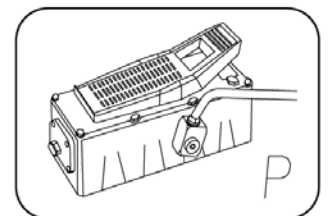
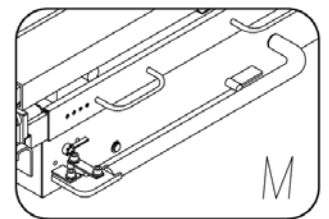

● Sollevatore  
Pont élévateur  
Lift  
Säulen

⊗ Rullo  
Galet  
Roller  
Rolle

# WERTHER



# 401 M/401 P

# 1,8 t

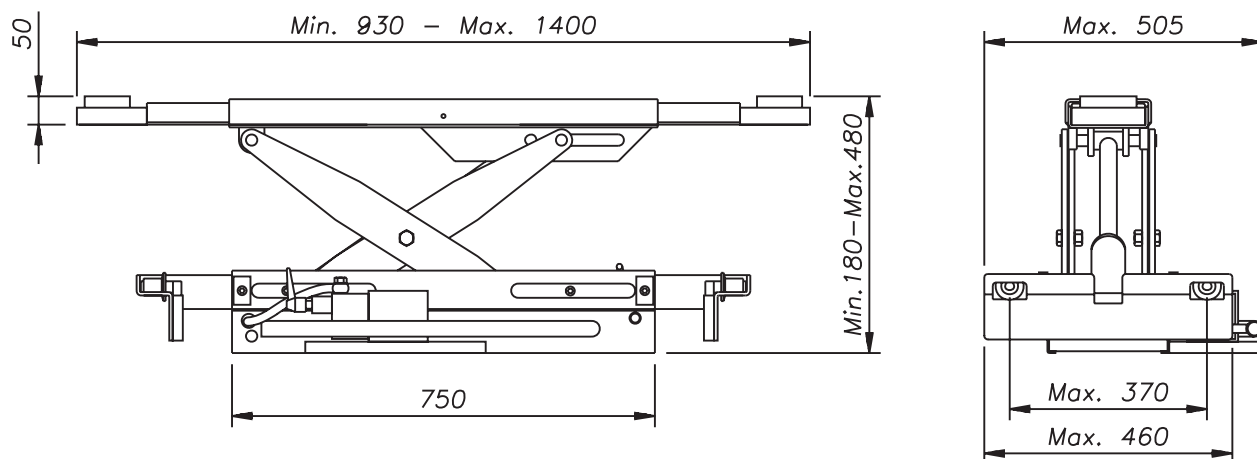

## Dati tecnici - Technical data - Caractéristiques techniques - Technische Eigenschaften

Portata • Capacity • Capacité • Hubkraft	1.800 kg
Spostamento vert. del carico • Lifting height • Hauteur de levée • Hubhöhe	300 mm
Estensione min.(bracci chiusi) • Min. extension (arms retracted) • Extension min. des bras (bras rentrés) • Min. Aufnahmebreite (Arme voll eingefahren)	930 mm
Estensione min.(bracci aperti) • Min. extension (arms extracted) • Extension max. des bras (bras sortis) • Min. Aufnahmebreite (Arme voll ausgefahren)	1.400 mm
Passo delle ruote di scorrimento min. • Wheel base min. • Pas des roulettes • Achsabstand der Laufrollen	800 mm
Passo delle ruote di scorrimento max. • Wheel base max. • Pas des roulettes • Achsabstand der Laufrollen, max.	1.200 mm
Peso della traversa • Weight • Poids • Gewicht	95 kg

## Opzioni - Optionals - Options - Sonderzubehör



- Kit appoggi per traversa
- Support kit for jacking beam
- Jeu de supports pour traverse
- Stützesatz für Achsfreiheber



- Estensioni per tamponi di sollevamento
- Lifting pad extensions
- Rallonges pour tampons de levage
- Hubspindelverlängerungen



### WERTHER INTERNATIONAL S.p.A.

Via F. Brunelleschi, 12 - 42040 Cadè (RE) Italy - Tel. ++39 0522 9431 - Fax ++39 0522 941997  
[www.wertherint.com](http://www.wertherint.com) - e-mail: [sales@wertherint.com](mailto:sales@wertherint.com)

Il fabbricante, nell'ambito del costante miglioramento dei propri prodotti, si riserva il diritto di apportare modifiche senza preavviso. - The company reserves the right to introduce improvements in design or specification without prior notice. - Der Hersteller behält sich das Recht vor, im Zuge der technischen Weiterentwicklung, technische Eigenschaften ohne Vorankündigung zu ändern. - Le fabriquant dans le but d'améliorer constamment ses produits, se réserve le droit d'apporter des modifications sans préavis - La compañía Werther se reserva de todos modos el derecho de aportar todas las modificaciones que considera necesarias para mejorar la estética o el funcionamiento de los productos, sin tener la obligación de avisar de ello.